

Toward a Derivational Typology*

Craig Sailor & Anoop Mahajan

UCLA

1. Introduction

Recent high-profile publications (Evans and Levinson 2009a, Dunn et al. 2011, a.o.) take aim at the theory of Universal Grammar (UG), arguing that it cannot be reconciled with the profound diversity of linguistic structures known to descriptive linguists. This is a common but misguided criticism of UG, which has never been a theory of surface representations. A more apt target, perhaps, is generative linguistics as a discipline: although much of it strives for descriptive adequacy,¹ its main focus has not been on accounting for important generalizations from e.g. word order typology (but see Cinque 2005, a.o.). Many of these generalizations do not directly lend themselves to a theoretical treatment: they are extrapolated strictly from linear orders, rather than underlying syntactic derivations, which could vary wildly across languages of the same superficial linear order (“type”).

Therefore, our goals in this paper are twofold. First, we argue that surface word order typology in the tradition of Greenberg (1963) is not adequate as a window into the proper understanding of syntactic diversity. In its place, we advocate the pursuit of a “derivational typology”, in which languages are classified by their major derivational properties. Under this approach, the various derivational types yield the known surface patterns, as well as many (and possibly all) exceptions to these patterns. Then, we offer a specific example of how the existing tools of syntactic theory can be used within this framework in order to capture a known correlation between the relative order of elements within VP and PP, and the relative order of VP and PP themselves.

2. The Misleading Nature of Surface Word Order Typology

Advances in linguistic typology have produced a number of significant surface word order generalizations since Greenberg’s (1963) seminal work, much of which is synthesized

*We would like to thank the participants and organizers of NELS 42. Abbreviations: COLL = collective; DEM = demonstrative; ERG = ergative; EXCL = exclusive; PAST = past tense; PostP = postpositional order; PrepP = prepositional order.

¹This is certainly not true of all generative work: see e.g. Chomsky (2004) for discussion.

by WALS Online (Dryer and Haspelmath 2011). The empirical foundation is a typology built on the strict but arbitrarily-defined notion of *dominant word order*: among all relative orderings of S(ubject), O(bject), and V(erb) within a language corpus, the dominant word order for that language is the one that is “more than twice as common as the next most frequent order” in the corpus (Dryer and Haspelmath 2011: supplement 6).² The word order types themselves (SVO, OV, etc.) have no linguistic status beyond their descriptive import; they are treated as grammatical primitives, and the syntactic sources of these orders are not factored into their classification.³

Of course, syntactic theory has changed significantly since Greenberg’s findings were first published. We now know that syntax is capable of generating a single surface word order in numerous ways. Distinct derivations can produce equally distinct surface constituencies, despite converging on a single superficial word order. If even just the basic tenets of the generative enterprise are valid, then the familiar word order types are not primitives: they are by-products of independently-motivated derivational operations (under strict Minimalist assumptions, (Re-)Merge).⁴

Inherently, each word order type (the “order of meaningful elements” in Greenberg 1963) often comprises a syntactically-heterogeneous set of languages as a result. That is, languages belonging to the same type often exhibit diverging syntactic properties. We conclude that a language’s dominant word order type (if it has one) in fact reveals very little of value about the actual structure of that language, meaning that these classifications can be, syntactically speaking, misleading and inaccurate.

We provide concrete examples illustrating this conclusion below, in the form of a pair of case studies involving the VSO and OVS word order types.

2.1 Case Studies: the VSO and OVS Types

First, consider Potsdam’s (2009) discussion of wh-question formation in VSO (and VOS) languages. Although these languages tend toward the same major syntactic properties, Potsdam notes that they differ in their strategies for achieving wh-initial order in questions. Depending on the language, wh-initial order arises from either canonical wh-movement, focus fronting, or (pseudo)clefting. On the surface, it is not at all clear what dictates a language’s preference for one strategy over the other, so this property seems to vary arbitrarily among members of this word order type.

Potsdam claims (following others) that suggestive patterns emerge when one compares these languages’ strategies for achieving wh-initial order with their strategies for achieving V-initial order. Summarizing a sizable literature on V-initial languages, he notes that V-initial order has at least four distinct derivational sources: V movement, (remnant) VP movement, subject lowering, and rightward specifiers (for VOS order). He argues that the derivation involved in each of these V-initial strategies has the effect of limiting the set

²If no such order can be found, then the language is described as “lacking a dominant word order” (*ibid.*).

³“Subject”, “object”, and “verb” also have primitive status, perhaps problematically; we leave this aside.

⁴These criticisms of surface word order generalizations are not new: they echo those raised in e.g. many of the cogent replies to Evans and Levinson (2009a). See *Behavioral and Brain Sciences* 32:5 and *Lingua* 120:12 for a few dozen such replies.

of wh-initial strategies available to a language, perhaps to the extent that a true implicational relationship exists between the two sets (e.g. “if VP movement, then clefting”). Note that this proposed implicational universal relates syntactic derivational steps. Progress of this sort can only be made through careful syntactic analysis; surface classification is not sensitive to patterns (including patterned exceptions) originating in the syntax.

Now consider a more detailed case study involving the major syntactic properties of OVS languages. Although Dryer and Haspelmath (2011: 81A) list only 11 languages with “dominant OVS order” (seven of which are spoken in South America), it is nevertheless a discrete word order type by their definition. One of these languages, Hixkaryana (Carib), is broadly similar to the other OVS languages in the region in terms of its major syntactic properties (Derbyshire and Pullum 1981). In particular, these languages are postpositional (1), and also allow SOV word order (2):

- (1) *Hixkaryana: OVS order, postpositions* (Derbyshire 1985: p. 60)
 biryekomo komo yonyetxkoni kamara **txetxa wawo** amnyehra
 child COLL he.was.eating.them jaguar forest in long.ago
 ‘The jaguar used to eat children in the forest long ago.’

- (2) *Hixkaryana: SOV order possible* (Derbyshire 1985: p. 74)
okomkurusu biryekomo heno yoskeko
 bushmaster child dead it.bit.him
 ‘It was a bushmaster (snake) that bit the child.’

Derbyshire (1985: p. 74) notes that clause-initial subjects in Hixkaryana are “emphatic”, and only licensed under certain discourse conditions (cf. *ibid.* §13.1). Adjuncts can also be fronted for emphasis, but only if the subject has not been; and, emphatic fronting is only available in matrix clauses. This cluster of properties strongly implicates a single, clause-initial A' position, very likely related to information structure.

If this is correct, and only a single constituent can be fronted for emphasis, then (2) indicates that OV order in Hixkaryana is not derived by emphatic fronting of O (see also Kalin 2011), which we return to shortly. It is also worth noting that many other properties of Hixkaryana (and neighboring OVS languages) are consistent with traditional head-final properties (e.g. their genitives, relative clauses, etc.: see Derbyshire 1985: §11.2). So far, then, our expectations have not been met: there is no sign of diverging syntactic properties among OVS-type languages. Instead, they seem to be well-behaved OV languages.

However, outside of South America, the OVS typology quickly breaks down. Consider Tuvaluan (Polynesian), whose dominant word order is also reported to be OVS (Dryer and Haspelmath 2011). First, Besnier (2000: p. 144) notes that postpositions are unattested in Tuvaluan, and that it is strictly prepositional (3). Second, SOV order is also unattested (4b):

- (3) *Tuvaluan: OVS order, prepositions* (Besnier 2000: p. 338)
 tamaliki ne afuli nee au **mai te lulu puaka**
 child PAST chase ERG I from the pen pig
 ‘I chased the children from the pig pen.’

(4) *Tuvaluan: SOV order impossible* (Besnier 2000: p. 131)

- a. te atu teelaa ne ffuti nee Niu
 the bonito DEM PAST pull ERG Niu
 ‘Niu landed that bonito (fish).’
- b. ***nee Niu te atu teelaa** ne ffuti
 ERG Niu the bonito DEM PAST pull

These Tuvaluan examples contrast sharply with their equivalents in Hixkaryana, (1)-(2). Moreover, in addition to its head-initial PPs, Tuvaluan exhibits many other canonical head-initial properties as well (Besnier 2000: p. 131).⁵ This sets it even further apart from Hixkaryana, despite that the two share OVS dominant word order.

In terms of their major structural properties, then, these two languages are quite dissimilar. They do, however, seem to share at least one major syntactic property – one that relates to a lingering question about Tuvaluan. That is, given Tuvaluan’s strong tendency toward head-initial configurations, how do we make sense of its OV surface order?

We argue that OVS arises in Tuvaluan when O has undergone A’-movement to a unique clause-initial position.⁶ This is precisely what we claimed for Hixkaryana’s subject-initial order (which we return to shortly), and we apply the same argumentation to support the claim for Tuvaluan, below, following a series of observations by Besnier (2000: p. 131-6).

First, Tuvaluan exhibits all possible surface word orders except SOV and OSV, the only orders in which both arguments are preverbal. Assume that the basic syntax of Tuvaluan, like its VSO relatives, involves movement of V(P) to a position higher than the subject (see Potsdam 2009 for references). If there is only one clause-initial position for fronted arguments (and adjuncts, which we leave aside), then it follows that SOV and OSV should be impossible in Tuvaluan: there is only room for one preverbal argument in the structure.

Second, preverbal arguments in Tuvaluan must be definite. This arises straightforwardly if preverbal arguments in the language have undergone topicalization, an A’ operation that non-definite DPs cannot undergo.⁷

Third, embedded clauses in Tuvaluan are obligatorily V-initial. Again, this is strongly reminiscent of an A’ operation: in many languages, such operations are prohibited in embedded contexts (e.g. embedded topicalization in English: Emonds 1976).

Finally, preverbal subjects (in SVO clauses) never bear ergative case, whereas they can (and typically do) elsewhere. Instead, when the subject is preverbal, an ergative-marked resumptive pronoun obligatorily appears postverbally. This is consistent with known constraints on A’-extraction in ergative languages: that is, ergative arguments are known to resist A’ operations in many languages (see Manning 1996), but resumptive pronouns (in languages that have them) often provide a means around this constraint. Crucially, operations such as relativization, which are uncontroversially A’ operations, also trigger resumption in Tuvaluan when targeting ergative-marked arguments (Besnier 2000: p. 66). Additionally, under the reasonable assumption that the resumptive pronoun occupies canonical subject

⁵In fact, apart from its curious preference for OVS order, Tuvaluan is effectively identical, typologically speaking, to its close Polynesian relatives (e.g. Samoan), which are overwhelmingly VSO.

⁶See Besnier (2000: §1.12 & 1.2.1) for the pragmatic effects of fronting arguments in Tuvaluan.

⁷If correct, it must be true of Tuvaluan that only one constituent can be topicalized per clause (see above).

position, its appearance postverbally lends further support to the claim that the Tuvaluan V ends up higher than non-A'-moved subjects.

Summing up, we claim that Tuvaluan's dominant O-initial order is derived by A'-movement of O from within an otherwise prototypical Polynesian VSO structure (which, of course, has its own complex derivation). Looking back at Hixkaryana, we claimed that it also had a unique, clause-initial A' position responsible for subject-initial (SOV) order. This implies that Hixkaryana OV order does not require A'-movement, unlike Tuvaluan; this explains why the former, but not the latter, allows two arguments to appear preverbally. Tuvaluan's head-initial properties are consistent with its VO configuration (before A' operations), while Hixkaryana's head-final properties are consistent with its OV configuration. If we could factor out Tuvaluan's O-fronting, then it could be properly re-classified.

2.2 Typological Opacity

Looking back at Hixkaryana and Tuvaluan, we see that the two share almost no structural similarities, and yet, under the going methodology, they belong to the same word order type. Because of its frequent but superficial O-fronting operation, Tuvaluan is improperly categorized as an OVS language, and thus, even more misleadingly, as an OV language. We refer to this state of affairs – whereby a syntactic process generates a surface word order pattern in a language that is inconsistent with its other major typological properties – as an instance of *typological opacity*. Specifically, a typologically opaque process is one that causes a deviation from what Cinque (to appear) calls the “abstract harmonic orders”, a definition which characterizes many, perhaps all, of the information-structural (A') movement operations. Of course, the existence of typologically opaque processes raises an important question: what are the processes that are typologically *transparent*? We take this up in §3.

Other well-known examples of typological opacity arise due to the verb-second (V2) phenomenon, e.g. in German, Dutch, etc. These languages are classified as “lacking dominant order among S, O, and V” by Dryer and Haspelmath (2011: 81A),⁸ putting most of Germanic on par with e.g. Warlpiri, typologically speaking. This is not a desirable outcome, given that German, Dutch, etc. are, for the most part, typical head-final languages. In traditional typology, they stand out as anomalous, even though the processes responsible for these “anomalies” are known to syntax, and not at all exotic. What we must do, then, is work to identify the sources of typological opacity, so that they may be factored out of our system of classification. The result would no longer be a typology of “surface word order”.

2.3 An Alternative: Toward a Derivational Typology

Given that surface word orders are epiphenomena of syntax, and on their own tell us very little about structure, the abundance of weak typological correlations and tendencies might simply reflect corresponding statistical noise. This noise could perhaps be greatly reduced if systems of linguistic classification were informed by linguistic theory (cf. Polinsky and

⁸Dryer and Haspelmath (2011: 81): “A third subtype of language lacking a dominant order consists of languages in which different word orders occur but the choice is syntactically determined.” We contend, of course, that syntax *always* determines word order.

Kluender 2007, Hermon 2009, Polinsky 2010, and particularly Koopman 2012), but the onus lies with generative linguistics to construct such systems, as Evans and Levinson (2009b: R2.3) and others point out.⁹

In place of word order typology, we propose a classification of the derivations that converge on these orders. This move toward what we call *derivational typology* should be concerned not just with capturing the surface generalizations, but also the patterned exceptions to those generalizations. We join a chorus of recent generative work expressing this sentiment (see fn. 9).

We sketch out a syntactic analysis consistent with these themes below.

3. Deriving Harmony

We have emphasized throughout that surface word order generalizations are often misleading. Still, the Greenbergian tradition has yielded a small number of such generalizations whose statistical correlations are extremely strong. These are also epiphenomenal, only they happen to reflect the final output of the core syntactic derivation.

We concern ourselves here with two such generalizations involving correlations between and within VPs and PPs.¹⁰ Specifically:

(5) *Relative order of VP and PP*

With overwhelming frequency, PPs appear on the same side of the verb as objects. Dryer (1992) notes VO-PP order in $\approx 98\%$ of VO languages (59 of 60), and PP-OV order in $\approx 88\%$ of OV languages (63 of 72).¹¹

(6) *Harmonious order across VP and PP*

With overwhelming frequency, VPs exhibit the same head-complement order as PPs. Dryer and Haspelmath (2011: 95A) observe PrepP in $\approx 92\%$ of VO languages (456 of 498), and PostP in $\approx 92\%$ of OV languages (472 of 514).

We aim to develop a theory of syntax that produces these correlations.¹²

3.1 Proposal

Assuming a small set of initial assumptions in (8), our claim is that the generalizations in (5)-(6) can be fully reduced to simple lexical variation of P. That is, feature-checking on P yields the headedness of PP, which in turn dictates the order in VP. Along the way, the

⁹A handful of recent work has taken up this charge, including Kayne (2000), Biberauer et al. (2007, and subsequent work), Potsdam (2009), and Biberauer and Sheehan (to appear). We offer our own attempt in §3.

¹⁰Throughout, we use the term “P(P)” to refer to adpositions (and their “objects”) generally. When the order of P and its “object” is relevant, we indicate this using the terms Prep(osition)P and Post(position)P.

¹¹In Dryer’s (1992) sample, 4 of the 9 languages exhibiting exceptional OV-PP order are in South America. Hixkaryana, a South American language, exhibits this exceptional pattern. See §3.4.

¹²See Kayne (2005: ch. 9) for similar goals, although our analyses differ in fundamental ways.

relative order of PP and VP also falls out as a consequence. This is a significant departure from the traditional assumption that the headedness of VP is privileged in the grammar.¹³

Formally, we encode the relevant lexical variation of P as a pair of strong (EPP) features (indicated with ‘*’), although this could be accomplished other ways (cf. Richards 2011). The going distinction between head-initial and head-final languages is stated below:¹⁴

(7) *The lexical variation of P*

- a. Head-initial languages: P bears [*uV**], attracts VP to [Spec, PP].
- b. Head-final languages: P bears [*uD**], attracts the “object” of P to [Spec, PP].¹⁵

Once we adopt the following proposals from the literature as our initial assumptions, the remaining surface correlations arise “for free” from syntax.

(8) *Initial assumptions*

- a. **Cyclic Linearization:** When a Spell-Out domain *X* is *linearized*, a set of *precedence relations* is created among each of the elements within *X* (e.g. *Y > Z*, “*Y* precedes *Z*”: Fox and Pesetsky 2005).
 - (i) Linearization of a Spell-Out domain *X* is triggered by merger of the head that selects *X* (signaling completion of that domain).
 - (ii) Extraction of an element from within a linearized domain creates precedence violations. The previously-established orders must be restored by additional movement before the next cycle (*Order Preservation*).
 - (iii) The Spell-Out domains are at least PP (see below) and CP, but *not* VP.
- b. **T-V adjacency:** T and V must be adjacent at some stage of the derivation (Holmberg 2000, Richards 2011, a.o.; see below).
- c. **P on the spine:** P is present in all clauses (overtly or non-overtly), merged on the clausal spine above VP (Kayne 1999 *et seq.*, Schweikert 2005).
- d. **OV in VP:** VPs can be head-final in first-merged base structure (Haider 2000).¹⁶

Following (Kayne 2005: ch. 7 & 9), prepositions select K, a head whose specifier licenses the “object” of P.¹⁷ K, in turn, selects VP, yielding the simplified clause structure in (9):

¹³Thus, we make a prediction for first language acquisition in languages with overt adpositions: children should acquire the order of heads and complements on the basis of data from PP, not VP. This question remains to be investigated.

¹⁴This implies that prepositions and postpositions are somehow distinct (sub)categories with different selectional properties. What we suggest here implies that prepositions have “verbal” selectional properties, while postpositions have “nominal” ones (but Hixkaryana P has both: see §3.4).

¹⁵We assume in (8c) that P is present in all clauses. If P is non-overt, then it attracts a silent DP.

¹⁶If we adopt the Antisymmetric view that all XPs are head-initial upon first merge, more would need to be said about the interaction of Cyclic Linearization and the T-V adjacency requirement. See fn. 20.

¹⁷See Kayne (2005: §7.1.2) for detailed discussion of KP. Strictly for reasons of derivational simplicity, we differ with *ibid.* §9.4.4, which states that the “object” of P never occupies [Spec, PP].

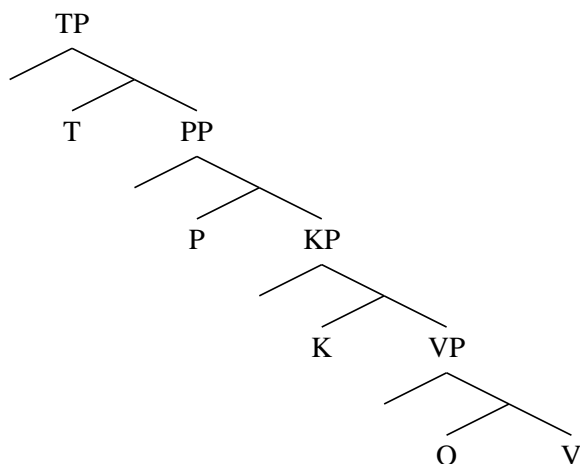
(9) *Simplified clause structure*

For concerns of space, we do not discuss the derivation of clauses containing more than one P; see Schweikert (2005). Likewise, we leave aside the position of subjects throughout our discussion, focusing only on the core derivation of VP and PP.

As stated in (8b), we follow previous work assuming that certain selectionally-related heads must be adjacent during the derivation. This has consequences for the linearization of syntactic objects that would otherwise disrupt adjacency at some stage of the derivation. For example, given a first-merge structure [X [ZP Y]], if X and Y must become adjacent, then ZP is an intervener. Various movement possibilities present themselves for achieving X-Y adjacency in this structure (e.g. ZP movement, Y-to-X movement, etc.). In the absence of independent evidence for such movements, we follow Richards (2011) in assuming that minimal structural changes are preferred, and that a linearization-based solution is plausible. That is, if the linear order of ZP and Y were simply reversed, then Y would be adjacent to X. (Likewise, starting from the initial structure above, X-Y adjacency could also be achieved if the linear order of X and YP were reversed). Richards refers to this linear reversal operation as *Rotate*, motivating it on prosodic grounds.¹⁸ For simplicity, we take this to be the operation responsible for deriving (some of) the adjacency effects seen in our system, perhaps ultimately owing to independent prosodic properties if Richards' approach is on the right track (though nothing crucially relies on this).

With these assumptions in place, we turn now to the derivation of VO-PrepP order.

¹⁸In brief, Richards argues that various theory-internal formal features, e.g. “strong” and EPP features, can be done away with, as they simply reflect re-ordering for predictable prosodic reasons (i.e., to satisfy the requirement that two selectionally-related elements be adjacent within the same level of phonological phrasing). *Rotate* achieves this re-ordering without movement: “you can tag a node X with a diacritic which is interpreted by phonology as meaning ‘If X c-commands Y, then X follows Y’” (Richards 2011: p. 18).

The same result could be achieved using e.g. Biberauer et al.’s (to appear) ‘L(inearization)-movement’ (movement of a head’s complement to its specifier for linearization purposes), though more would need to be said about the timing of such movement within a Cyclic Linearization approach.

3.2 The Derivation of VO-PrepP Order

Languages exhibiting this order have P [uV^*], triggering movement of VP to [Spec, PP]. Upon merger of T, the object is an intervener for T-V adjacency, necessitating a VP-internal reordering (i.e., Rotate). This applies simultaneously with Spell-Out of PP, and Order Preservation is respected.

(10) *Deriving VO-PrepP*

- a. Merge P [uV^*]: attract VP

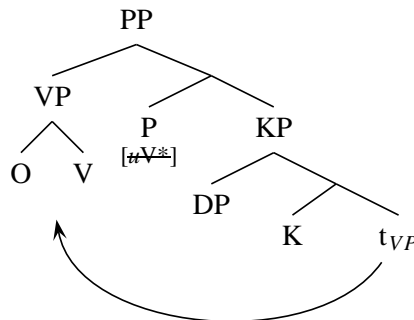

- b. Merge T: triggers Rotate of VP (T-V adjacency) and Spell-Out of PP

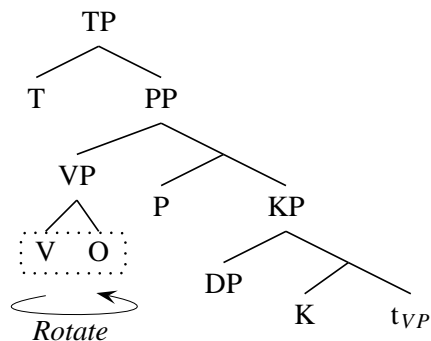

This derivation yields head-initial surface order for VP and PP (recognizing that the latter is not a simplex constituent), as well as VP-PrepP order, in accordance with the generalizations in (5) and (6).

We turn now to the derivation of PostP-OV order.

3.3 The Derivation of PostP-OV Order

Languages exhibiting this order have P [uD^*], triggering movement of the DP “object” of P to [Spec, PP]. The remainder of the derivation – which involves movement of VP followed by remnant-movement of PP – arises from satisfaction of the T-V adjacency requirement and Cyclic Linearization.

(11) *Deriving PostP-OV*

- a. Merge P [uD^*]: attract DP (PostP order)

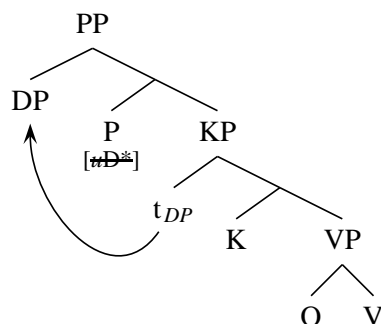

- b. Merge T: triggers Spell-Out of PP, fixing the relative order of the elements inside PP; however, T-V adjacency forces VP to move, creating precedence violations (e.g. P < VP).²⁰

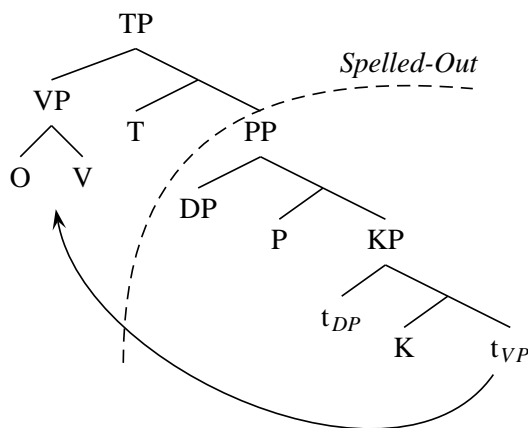

²⁰If we take the Antisymmetric view that all XPs start out head-initial, then the derivation of PostP-OV order (11b) becomes problematic: VP movement would fail to yield T-V adjacency by itself (O would intervene), and precedence within VP would presumably be fixed at Spell-Out of PP, meaning Rotate could not apply. (Rotating VP prior to Spell-Out of PP would require “lookahead”, which is to be avoided.)

Fox and Pesetsky’s (2005) discussion of ellipsis offers a potential solution. They argue that deleting a linearized constituent also deletes all precedence relations established among elements within that constituent (correctly allowing “repair by deletion”). If Move is actually Re-Merge, and lower copies of a displaced XP are deleted, then, by analogy to ellipsis, this ought to entail deletion of all precedence relations within any moved XP. If correct, then moving a linearized VP would “feed” Rotate, allowing T-V adjacency to be established. This approach makes a number of testable predictions, but we must leave them for future work.

- c. The P < VP precedence established in the prior cycle must be restored before the end of the next cycle, requiring remnant movement of PP across VP.²¹

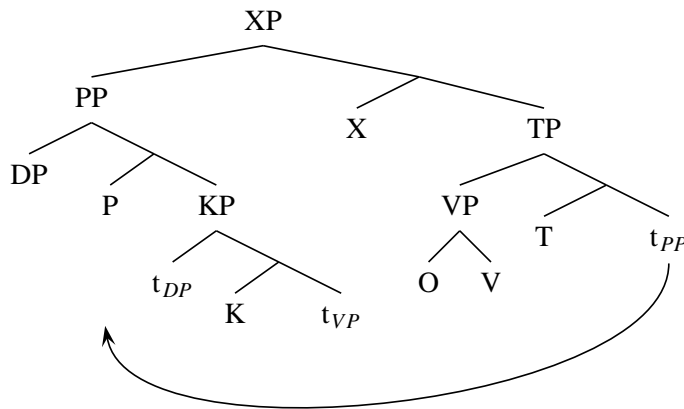

Following this movement of PP, Order Preservation is satisfied: P precedes VP. Thus, given our initial assumptions in (8), simple feature-checking on P leads directly to the generalizations in (5) and (6). It also yields a head-final configuration for T, consistent with the facts for many languages with PostP-OV order.

3.4 Deriving an Exception: OV-PostP Order (Hixkaryana)

Hixkaryana (and neighboring languages) exhibits OV-PostP order (see fn. 11), which stands in exception to (5). Exceptional patterns such as this can also be made to follow from minor lexical variation of P, consistent with our proposal in §3.1.

Specifically, we suggest that OV-PostP languages have a P with nominal and verbal selectional properties (see fn. 14). That is, it bears [*uD**, *uV**], meaning it attracts both the DP “object” of P to its specifier (deriving postpositional order) as well as the VP:²²

(12) Deriving exceptional OV-PostP

- a. Merge P [*uD**, *uV**]: attract DP (PostP order)...

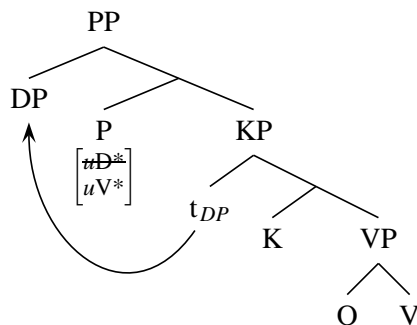

²¹We do not commit ourselves to a label for XP, although several options present themselves. For our purposes, all that matters is that this XP is lower than CP, the highest Spell-Out domain in the clause.

²²This requires multiple specifiers, unlinearizable by the LCA (or by its mirror image, Rotate). However, this conflict is resolved before Spell-Out: see (12c). Note that the relative order of these specifiers is irrelevant for our purposes (although we assume that DP occupies the lower specifier).

b. ...and attract VP

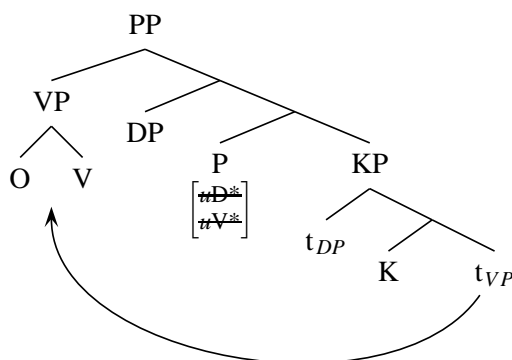
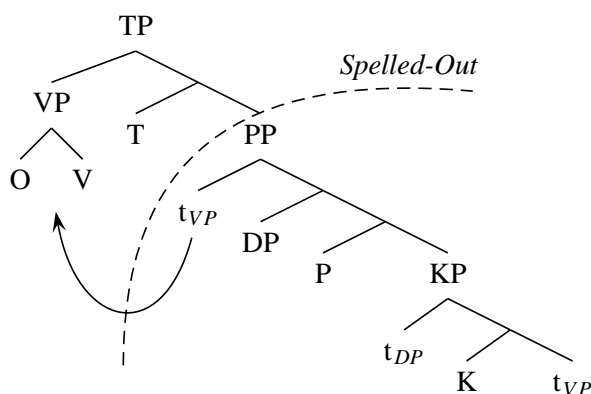
c. Merge T: triggers Spell-Out of PP, fixing the relative order of the elements inside PP; however, T-V adjacency forces VP movement.²³

This yields exceptional OV-PostP order. Unlike canonical head-final languages, those of the Hixkaryana type do not involve movement of PP: this is a direct consequence of the features on P. Thus, the rarity of this OV-PostP type reduces to the rarity of P bearing $[uD^*, uV^*]$. Exactly why this feature should be rare, though, remains an open question.

4. Closing Remarks

In essence, we claim that the typological generalizations in (5) and (6) arise as the result of a sort of “Generalized Holmberg’s Generalization” – the idea that precedence relations established for major constituents early in a derivation must persist through later stages.²⁴ This is the major contribution of Fox and Pesetsky (2005), and if it is correct, then we expect to see such effects arising in many other places in grammar. We believe that this is a promising route toward capturing important typological generalizations (and their exceptions) from basic properties of syntax.

²³We are left to explain why VP moves, instead of simply undergoing Rotate in [Spec, PP]. We conjecture that this is due to the position of the Subject in the derivation (which we have left aside for concerns of space): given Hixkaryana’s OVS order, we suggest that the Subject occupies a position between TP and PP, making it an intervener for V-T adjacency, even if Rotate were to apply.

²⁴Cf. Richards’ (2011: p. 13) notion of *Mitigated Ruthlessness*.

References

- Besnier, Niko. 2000. *Tuvaluan*. Routledge.
- Biberauer, Theresa, Anders Holmberg, and Ian Roberts. 2007. Disharmonic word-order systems and the Final-over-Final-Constraint. In *The proceedings of XXIII Incontro di Grammatica Generativa*, ed. A. Bisetto and F. Barbieri, 86–105.
- Biberauer, Theresa, Anders Holmberg, and Ian Roberts. To appear. A syntactic universal and its consequences. *Linguistic Inquiry* to appear.
- Biberauer, Theresa, and Michelle Sheehan, ed. To appear. *Theoretical approaches to disharmonic word order*. Oxford: Oxford University Press.
- Chomsky, Noam. 2004. Beyond explanatory adequacy. In *Structures and beyond*, ed. Adriana Belletti, volume 3 of *The Cartography of Syntactic Structures*, chapter 3, 104–131. Oxford University Press.
- Cinque, Guglielmo. 2005. Deriving Greenberg's Universal 20 and its exceptions. *Linguistic Inquiry* 36:315–332.
- Cinque, Guglielmo. To appear. Word order typology: a change in perspective. In *Theoretical approaches to disharmonic word order*, ed. Theresa Biberauer and Michelle Sheehan. Oxford: Oxford University Press.
- Derbyshire, Desmond. 1985. *Hixkaryana and linguistic typology*. Summer Institute of Linguistics.
- Derbyshire, Desmond, and Geoffrey Pullum. 1981. Object-initial languages. *International Journal of American Linguistics* 47:192–214.
- Dryer, Matthew S. 1992. The Greenbergian word order correlations. *Language* 68:81–138.
- Dryer, Matthew S., and Martin Haspelmath, ed. 2011. *The world atlas of language structures online*. <http://wals.info/>. Munich: Max Planck Digital Library.
- Dunn, Michael, Simon J. Greenhill, Stephen C. Levinson, and Russell D. Gray. 2011. Evolved structure of language shows lineage-specific trends in word-order universals. *Nature* 473:79–82.
- Emonds, Joseph. 1976. *A transformational approach to English syntax: Root, structure-preserving, and local transformations*. New York: Academic Press.
- Evans, Nicholas, and Stephen C. Levinson. 2009a. The myth of language universals: language diversity and its importance for cognitive science. *Behavioral and Brain Sciences* 32:429–448.
- Evans, Nicholas, and Stephen C. Levinson. 2009b. With diversity in mind: Freeing the language sciences from Universal Grammar. *Behavioral and Brain Sciences* 32:472–484.
- Fox, Daniel, and David Pesetsky. 2005. Cyclic linearization of syntactic structure. *Theoretical Linguistics* 31:1–45.
- Greenberg, Joseph. 1963. Some universals of grammar with particular reference to the order of meaningful elements. In *Universals of human language*, 73–113. Cambridge, MA: MIT Press.
- Haider, Hubert. 2000. OV is more basic than VO. In *The derivation of VO and OV*, ed. Peter Svenonius, 45–67. John Benjamins.
- Hermon, Gabriella. 2009. Language typology and universal grammar: a commentary on

- the paper by Eric Potsdam. *Natural Language & Linguistic Theory* 27:773–787.
- Holmberg, Anders. 2000. Deriving OV order in Finnish. In *The derivation of VO and OV*, ed. Peter Svenonius, 123–152. John Benjamins.
- Kalin, Laura. 2011. Hixkaryana: The derivation of Object Verb Subject word order. Master's thesis, UCLA.
- Kayne, Richard. 1999. Prepositional complementizers as attractors. *Probus* 11:39–73.
- Kayne, Richard. 2000. A note on prepositions, complementizers, and word order universals. In *Parameters and universals*, chapter 15, 314–326. Oxford University Press.
- Kayne, Richard. 2005. *Movement and silence*. Oxford University Press.
- Koopman, Hilda, ed. 2012. *Syntactic and semantic structures of the world's languages*. <http://sswl.railsplayground.net/>.
- Manning, Christopher. 1996. *Ergativity: Argument structure and grammatical relations*. CSLI Publications.
- Polinsky, Maria. 2010. Linguistic typology and formal grammar. In *The Oxford handbook of typology*, ed. Jae Jung Sung. Oxford University Press.
- Polinsky, Maria, and Robert Kluender. 2007. Linguistic typology and theory construction: Common challenges ahead. *Linguistic Typology* 11:273–283.
- Potsdam, Eric. 2009. Austronesian verb-initial languages and wh-question strategies. *Natural Language & Linguistic Theory* 27:737–771.
- Richards, Norvin. 2011. Generalized contiguity. Presented at the 29th West Coast Conference on Formal Linguistics.
- Schweikert, Walter. 2005. *The order of prepositional phrases in the structure of the clause*. John Benjamins.

UCLA Department of Linguistics
3125 Campbell Hall
Los Angeles, CA 90095-1543

cwsailor@ucla.edu
amahajan@ucla.edu